

# “NORMAREN” TYPE CELLS

## TRANSFORMATION CENTERS OF MEDIUM VOLTAGE FOR SIGNALING OF RAILWAY LINES



Cabinets with nominal voltage of 3.6 kV, intended for transformation centers with double (loop) supply, with cables up to 35 mm<sup>2</sup> in section and a protected output.

This transformation center is constituted by:

- **STEEL CABINET.**
- **ELECTRICAL SWITCHGEAR:** three bipolar switch-disconnectors (type **MOL-2** and **MOL-2 / C**) or three three-pole disconnect switches (type **MOL-3F** and **MOL-3F / C**).
- **TRANSFORMER** of reducing power of up to 50 kVA.

### OPERATING SCHEME

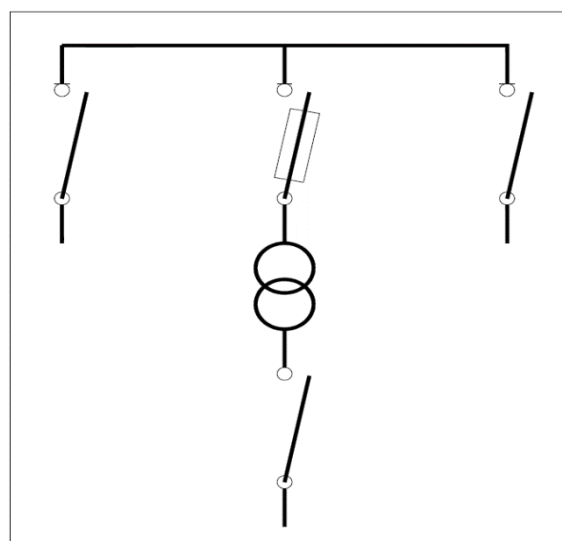

## CABINET

The cabinet is made of 2.5 mm thick sheet steel, bent and welded conveniently to form a very resistant assembly. It has a hot galvanized finish to prevent corrosion.

The whole is closed by a door that rests on robust welded hinges. The maximum opening of the door is 270 ° (completely folded down on the side of the device) and is provided with a hook so that it can be locked with an angle of rotation of approximately 100 °. Both the front part of the cabinet (door) and the back part have double slots, protected by metal mesh, provided for proper ventilation.

The door, with neoprene rubber gasket, is closed with a handle that operates three locks: one upper, one lower and one third lateral. The door can be closed with a padlock.

On the side walls and at the bottom of the cabinet there are grooved, welded profiles, on which the switches and the transformer are then mounted.

On the right side is welded a threaded pin with M8 nut for grounding (Tightening torque 6 N·m). The base of the cabinet has 4 fixing holes Ø 22 mm (Tightening torque 250 N·m).

### CABINET DIMENSIONS (mm)

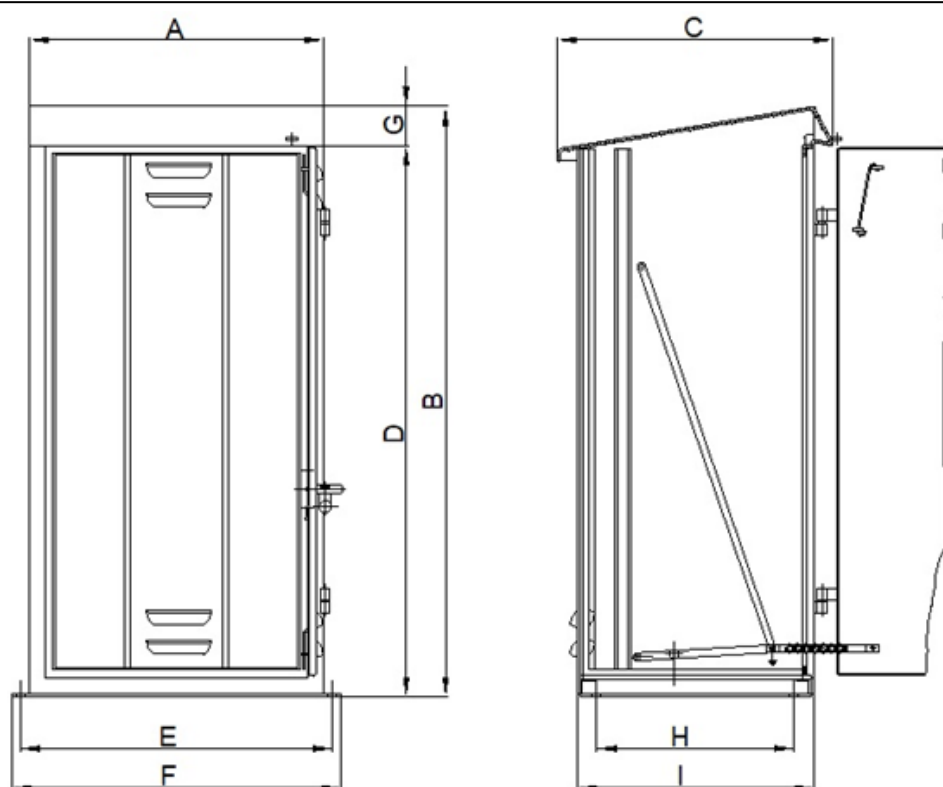

	A	B	C	D	E	F	G	H	I
NR1	750	1100	675	1000	795	834	100	500	600
NR2	750	1500	675	1400	795	834	100	500	600
NR3	850	1600	925	1500	895	934	100	750	850
NR4	850	2000	925	1900	895	934	100	750	850
NR5	1050	1500	675	1400	1095	1134	100	500	600
NR6	1050	1100	675	1000	1095	1134	100	500	600
NR7	1050	1600	925	1500	1095	1134	100	750	850

**Table 1.** Dimensions of the most common models.

## OPERATING VARIANTS

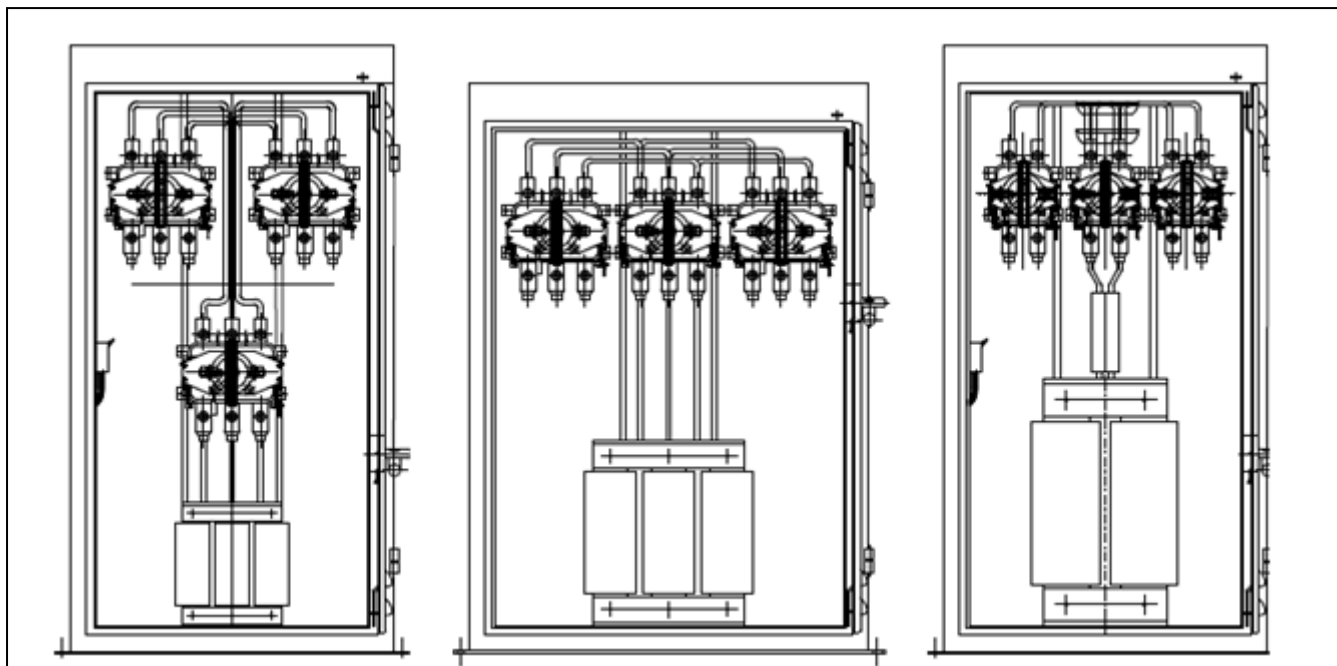

As table 1 shows, the cabinet model and the interior layout of this will be determined by the characteristics requested.

There is the possibility of manufacturing models different from those shown in the previous table. Consult required characteristics.

## ELECTRICAL SWITCHGEAR

Mainly, composed of three double-break dry-disconnect switches, encapsulated in epoxy resin. Two of them for loop feeding and one equipped with fusible cartridges for transformer protection. Bipolar type **MOL-2** and **MOL-2/C** and tripolar type **MOL-3F** and **MOL-3F/C**.

### CHARACTERISTICS MOL-2 & MOL-2/C

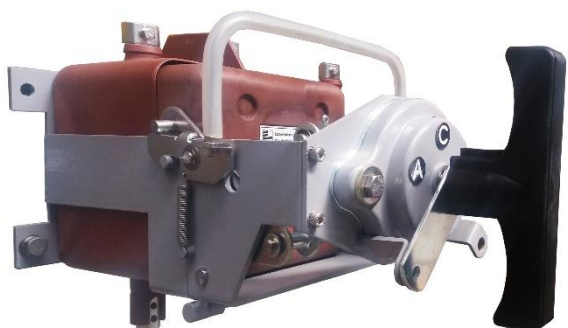

Denomination _____	MOL-2 bipolar MOL-2/C bipolar
Product Standards _____	UNE-EN 62271-103
Rated Voltage _____	3,6 kV
Rated Current _____	200 A
Isolation level _____	12/46 kV/kV
Rated breaking current _____	200 A
Short-time thermal current (1s) _____	3000 A
Rated dynamic current _____	7500 Â
Making power in c.c. _____	7500 Â
Mechanical Endurance _____	More than 1000 operating cycles
Degree of protection _____	IPH3, according to 20099 (With mobile body removed, the degree of protection of the fixed body is IPH2).

## CHARACTERISTICS MOL-3F & MOL-3F/C

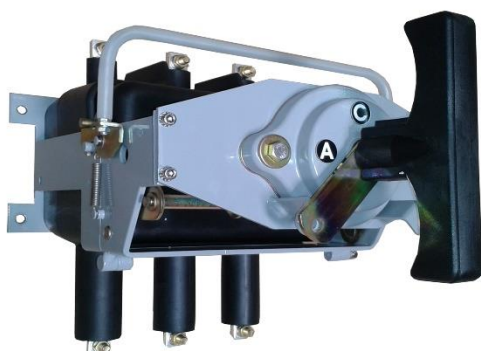

Denomination _____	MOL-3F, MOL-3F/C
Product Standards _____	IEC 62271-103
Rated Voltage _____	3,6 kV
Rated Current _____	125 A
Isolation level _____	40/46 kV/kV
Rated breaking current _____	125 A
Short-time thermal current (1s) _____	2 kÂ
Rated dynamic current _____	5 kÂ
Making power in c.c. _____	2 kA
Mechanical Endurance _____	More than 1000 operating cycles
Degree of protection _____	IPH3, according to 20099 (With mobile body removed, the degree of protection of the fixed body is IPH2).

## DESCRIPTION MOL

The MOL switch is a set encapsulated in resin, consisting of a fixed body and another mobile that slides on the previous one, according to the hip-flask system, and mounted on a frame with 4 holes for its fixation on a vertical surface by screws M8x30.

A control device by lever and spring makes the moving body slide over the fixed one, effecting in this way the sudden making and breaking operations, independent of the operator.

A system of triggers with springs and hinges allows the total extraction of the moving part, exposing the insulating nozzles of the fixed contacts.

The control lever allows locking the spring device in the open position or the closed position.

The fixed body is the fixed contact carrier. The fixed contacts are inserted in the epoxy resin during the casting process. Each fixed contact is screwed to a contact holder. The whole is enclosed by a nozzle of insulating material.

The mobile body contains the moving contacts, with copper-tungsten head as arc extinguishing element. Every two contacts, which constitute a phase, are joined by a copper plate for the MOL switch and by a clamp set and fusible cartridges for the MOL/C type.

A letter "A" is incorporated in the command plate support pointing the open position (disconnected) and the letter "C" indicates the coded position (connected), in alignment with the own joystick.

The name plate is made of insulating material and is placed on the front of the mobile body.

The input terminals of the switch allow two conductors to be connected by means of a flange and the output ones by a conductor by means of Allen-type fixing screws.

These terminals are protected by insulating caps that can slide on the conductors and are provided with a hole that allows the voltage check.

### DIMENSIONS MOL-2 (mm)

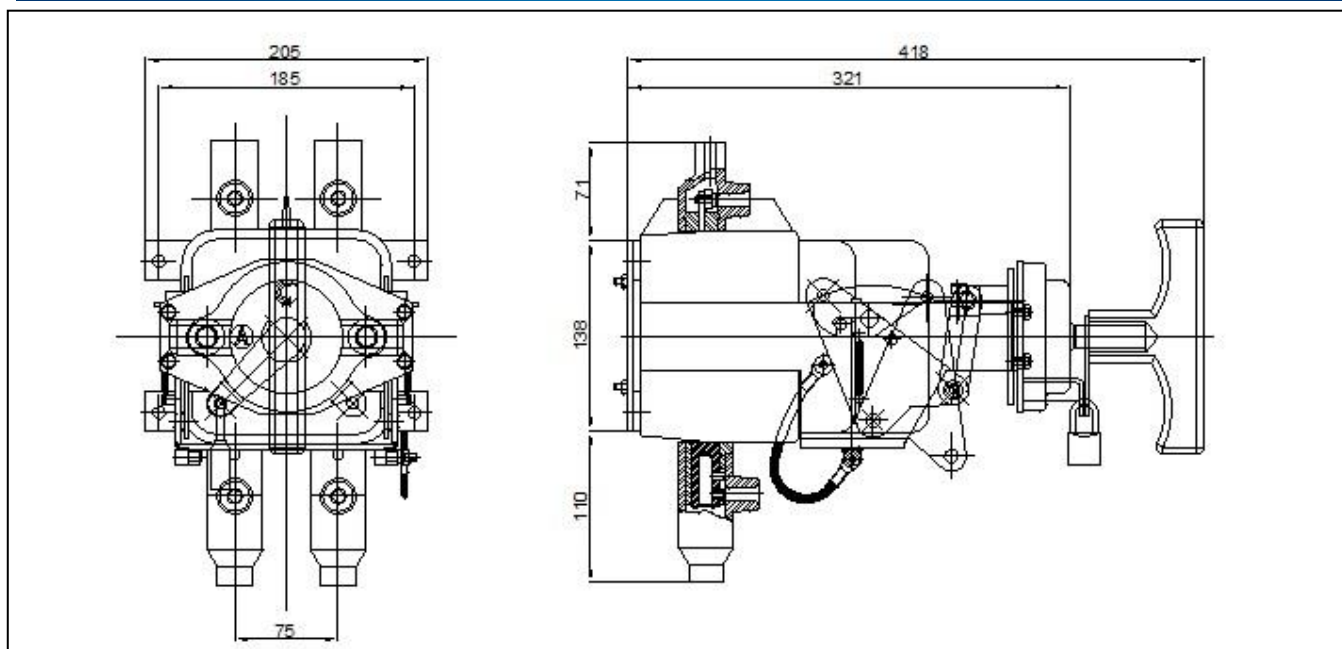

### DIMENSIONS MOL-3 (mm)

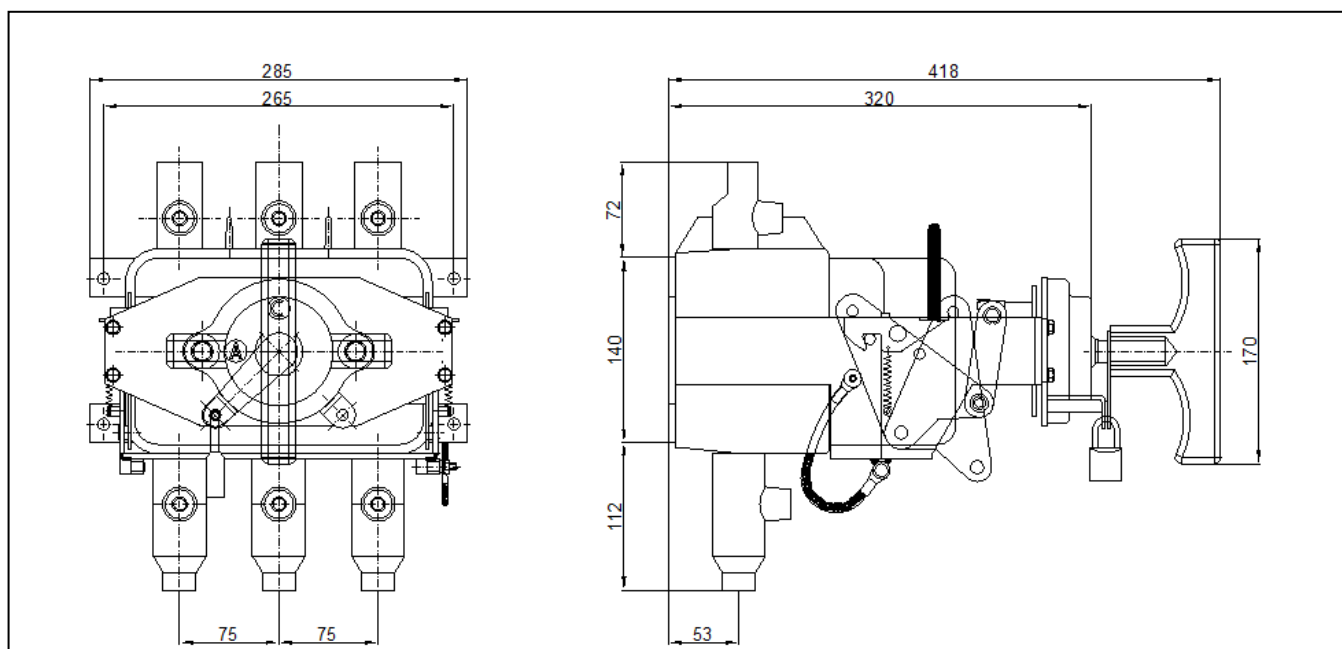

### MAINTENANCE MOL-2 / MOL-3F

The maintenance of this device is very simple. The mechanical part should be greased every 4 or 5 years. In the electrical part, the moving contacts have to be replaced when it is observed that the tungsten head thereof has been reduced due to wear to one third of its initial volume, approximately 1.5 mm.

Spare parts:

Description	Reference	Qty.	
		Mol-2	Mol-3F
Fixed contact	IR3-915	4	6
Mobile contact	IR3-914	4	6
Nozzle	IR2-805	4	6

## TRANSFORMER

Complete the "NORMAREN" cell assembly, a power transformer for indoor service, manufactured according to IEC 60076 standards.

**The cell can be supplied with the transformer or without it, at the customer's request.**

### DESCRIPTION

Power transformer from 0.5 kVA to 50 kVA depending on the required characteristics.

In the transformers the active part is completely occluded in epoxy resin.

It has great resistance to mechanical shocks and is unassailable for moisture, dust and most chemical agents.

